



Description

The PJ1117 Series are low-dropout three-terminal Linear regulator circuit with positive voltage output. They are divided into two versions, fixed voltage output version and adjustable voltage output version: The fixed output voltage is 1.2V, 1.8V, 2.5V, 3.3V, 5V and the adjustable version can provide the output voltage from 1.25V to 12V with only 2 external resistors.

Features

- Quiescent Current: 2mA(Typ.)
- Maximum Output Current: 1.0A
- Range of Operation Input Voltage: Max.15V
- Current Limiting
- Thermal Shutdown
- Operation Ambient Temperature: -40~85°C
- Available Packages: SOT-89, SOT-223, TO-252

Applications

- LCD Monitor and LCD TV
- DVD Decode Boar
- ADSL Modem

Typical Application Circuit

The PJ1117 Series have adjustable version and six fixed versions (1.2V, 1.8V, 2.5V, 3.3V and 5V)

Fixed Voltage Output Version

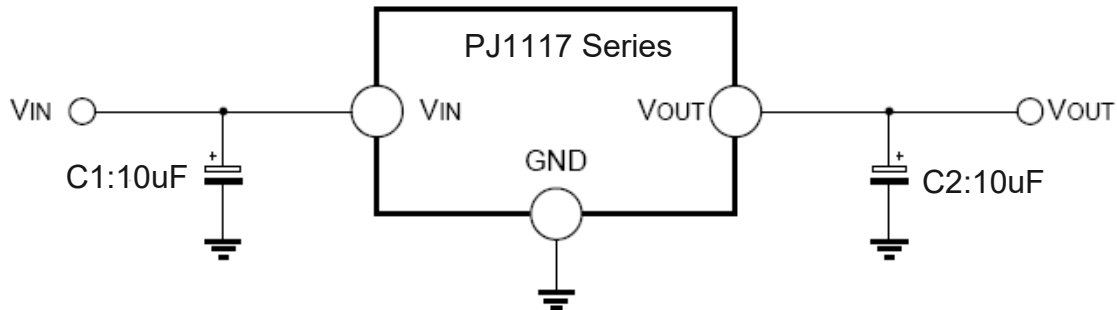

1. Recommend using 10uF tan capacitor as bypass capacitor (C1) for all application circuit.
2. Recommend using 10uF tan capacitor to assure circuit stability.

Adjustable Voltage Output Version

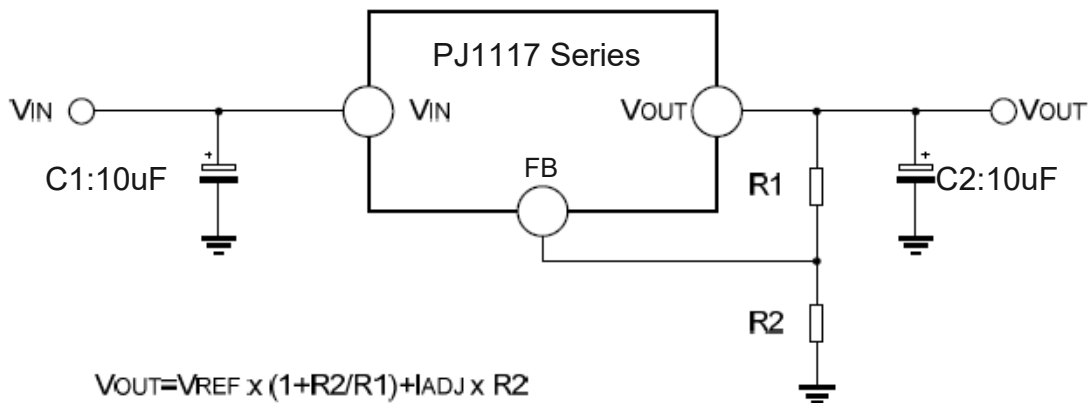

The output voltage of adjustable version follows the equation: $V_{OUT} = 1.25 \times (1 + R2/R1) + I_{ADJ} \times R2$. We can ignore I_{ADJ} because I_{ADJ} (about 50uA) is much less than the current of $R1$ (about 2~10mA).

- (1). To meet the minimum load current (>10mA) requirement, $R1$ is recommended to be 125Ω or lower. As PJ1117XX-ADJ can keep itself stable at load current about 2mA, $R1$ is not allowed to be higher than 625Ω.
- (2). Using a bypass capacitor (C_{ADJ}) between the FB pin and ground can improve ripple rejection. This bypass capacitor prevents ripple from being amplified as the output voltage is increased. The impedance of C_{ADJ} should be less than $R1$ to prevent ripple from being amplified. As $R1$ is normally in the range of 100Ω~500Ω, the value of C_{ADJ} should satisfy this equation: $1/(2\pi \times f_{ripple} \times C_{ADJ}) < R1$.

Pin Distribution

SOT-89

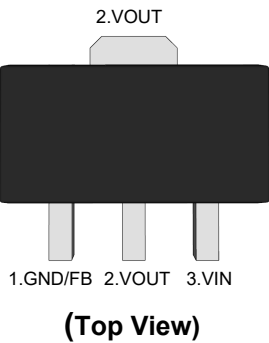

SOT-223

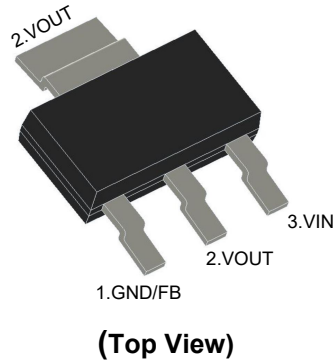

TO-252

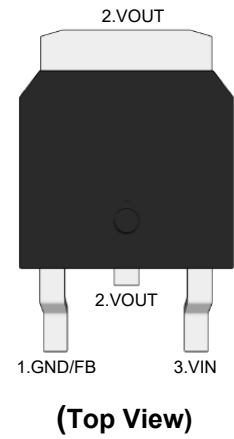

Functional Pin Description

Pin Name	Pin Function
GND/ADJ	Ground/Adjustable Pin
VOUT	Output Voltage
VIN	Power Input Voltage

Ordering Information

PJ1117 □□ - □□

Fixed Voltage Output Version
 1.2 : 1.2V 1.8 : 1.8V 2.5 : 2.5V 3.3 : 3.3V 5.0 : 5.0V
 Adjustable Voltage Output Version
 ADJ: $V_{FB}=1.25$

Package Type
 SQ: SOT-89 ST: SOT-223 TE: TO-252



PJ1117 Series Low Dropout Regulators

Ordering Information

Orderable Device	Package	Reel (inch)	Package Qty (PCS)	Eco Plan ^{Note}	MSL Level	Marking Code
PJ1117SQ-1.2	SOT-89	7/13	1000/3000	RoHS & Green	MSL1	<p>The "XX" is variable PJ1117SQ-1.2 = 1117 -1.2 PJ1117SQ-1.8 = 1117 -1.8 PJ1117SQ-2.5 = 1117 -2.5 PJ1117SQ-3.3 = 1117 -3.3 PJ1117SQ-5.0 = 1117 -5.0 PJ1117SQ-ADJ = 1117 -AJ</p>
PJ1117SQ-1.8						
PJ1117SQ-2.5						
PJ1117SQ-3.3						
PJ1117SQ-5.0						
PJ1117SQ-ADJ						
PJ1117ST-1.2	SOT-223	13	4000	RoHS & Green	MSL3	<p>The "XX" is variable PJ1117ST-1.2 = 1117 -1.2 PJ1117ST-1.8 = 1117 -1.8 PJ1117ST-2.5 = 1117 -2.5 PJ1117ST-3.3 = 1117 -3.3 PJ1117ST-5.0 = 1117 -5.0 PJ1117ST-ADJ = 1117 -AJ</p>
PJ1117ST-1.8						
PJ1117ST-2.5						
PJ1117ST-3.3						
PJ1117ST-5.0						
PJ1117ST-ADJ						
PJ1117TE-1.2	TO-252	13	2500	RoHS & Green	MSL3	<p>"XX" and "YW" are variable PJ1117TE-1.2 = 111712 YW PJ1117TE-1.8 = 111718 YW PJ1117TE-2.5 = 111725 YW PJ1117TE-3.3 = 111733 YW PJ1117TE-5.0 = 111750 YW PJ1117TE-ADJ = 1117AJ YW</p>
PJ1117TE-1.8						
PJ1117TE-2.5						
PJ1117TE-3.3						
PJ1117TE-5.0						
PJ1117TE-ADJ						

Note:

RoHS: PJ defines "RoHS" to mean semiconductor products that are compliant with the current EU RoHS requirements for all 10 RoHS substances, including the requirement that RoHS substance do not exceed 0.1% by weight in homogeneous materials.

Green: PJ defines "Green" to mean Halogen-Free and Antimony-Free.

Function Block Diagram

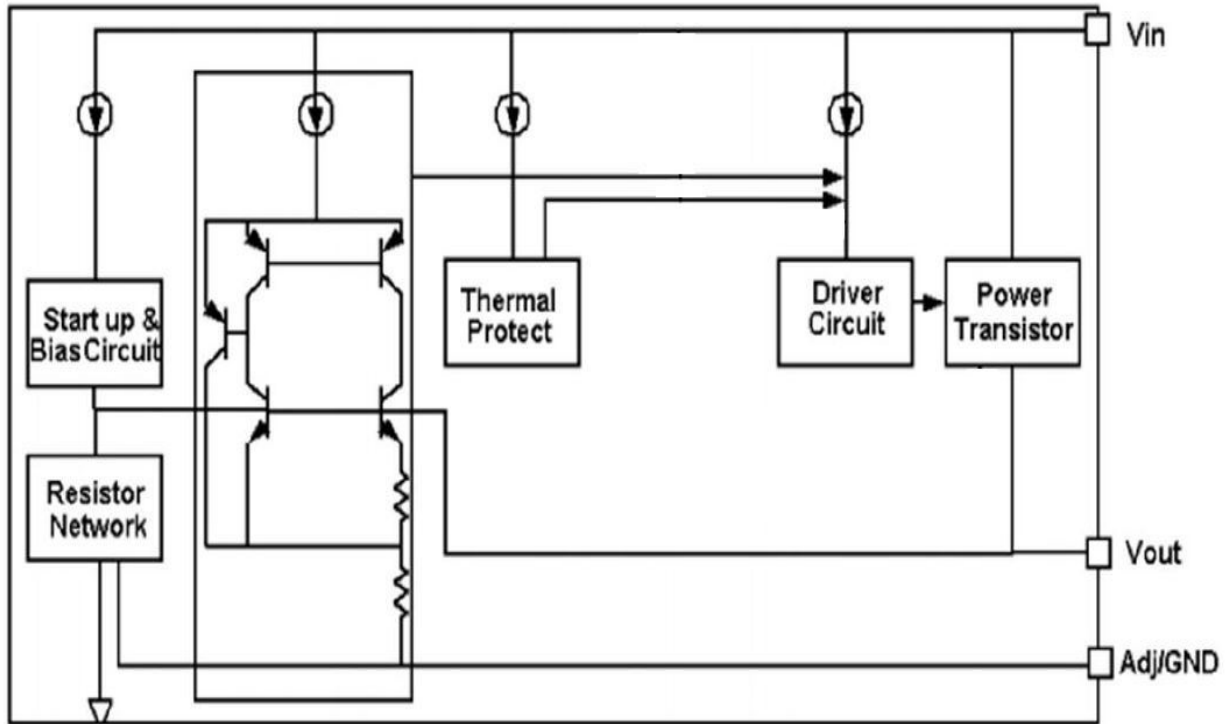



Absolute Maximum Ratings ^{Note1}

Ratings at 25°C ambient temperature unless otherwise specified.

Parameter	Symbol	Rating	Unit
Supply Voltage	V _{IN}	18	V
Maximum Output Current	I _{OUT}	1	A
Power Dissipation ^{Note2}	P _D	Internally Limited	--
Thermal Resistance Junction-to-Case	SOT-89	45	°C/W
	SOT-223	20	°C/W
	TO-252	12.5	°C/W
Junction Temperature	T _J	150	°C
Storage Temperature	T _{STG}	-40 to +150	°C
Lead Temperature & Time	T _L	260°C, 10S	--

Note:

1. These are stress ratings only. Stresses exceeding the range specified under Absolute Maximum Ratings may cause substantial damage to the device. Functional operation of this device at other conditions beyond those listed in the specification is not implied and prolonged exposure to extreme conditions may affect device reliability.
2. The Power Dissipation is : $P_D = (T_{J(MAX)} - T_C) / R_{\theta JC}$

Recommended Operating Conditions

Parameter	Symbol	Rating	Unit
Recommended Maximum Input Voltage	V _{IN}	15	V
Recommended Operating Junction Temperature	T _{opr}	-40 to +85	°C

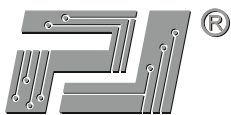

Fixed Voltage Output Version

Electrical Characteristics

($T_A=25^{\circ}\text{C}$, unless otherwise noted.)

Parameter	Symbol	Test Conditions	Min.	Typ.	Max.	Unit
Output Voltage Accuracy	ΔV_{OUT}	$0 \leq I_{\text{OUT}} \leq 1\text{A}, V_{\text{IN}} = V_{\text{OUT}} + 2\text{V}$	-2	--	+2	%
Quiescent Current	I_{Q}	$V_{\text{OUT}} = 1.2\text{V}$ $I_{\text{OUT}} = 0\text{mA}, V_{\text{IN}} = 10\text{V}$	--	2	5	mA
		$1.8\text{V} \leq V_{\text{OUT}} \leq 5\text{V}$ $I_{\text{OUT}} = 0\text{mA}, V_{\text{IN}} = 12\text{V}$	--	2	5	mA
Dropout Voltage	V_{DROP}	$I_{\text{OUT}} = 100\text{mA}$	--	1.15	1.3	V
		$I_{\text{OUT}} = 1\text{A}$	--	1.3	1.5	V
Line Regulation	ΔV_{LINE}	$V_{\text{OUT}} = 1.2\text{V}$ $I_{\text{OUT}} = 10\text{mA}, 2.7\text{V} \leq V_{\text{IN}} \leq 10\text{V}$	--	0.03	0.2	%V
		$1.8\text{V} \leq V_{\text{OUT}} \leq 5\text{V}$ $I_{\text{OUT}} = 10\text{mA}, V_{\text{OUT}} + 1.5\text{V} \leq V_{\text{IN}} \leq 12\text{V}$	--	0.03	0.2	
Load Regulation	ΔV_{LOAD}	$10\text{mA} \leq I_{\text{OUT}} \leq 1\text{A}, V_{\text{IN}} = V_{\text{OUT}} + 1.5\text{V}$	--	--	36	mV
Temperature coefficient	$\Delta V/\Delta T$		--	+100	--	ppm

Adjustable Voltage Output Version

Electrical Characteristics

($T_A=25^{\circ}\text{C}$, unless otherwise noted.)

Parameter	Symbol	Test Conditions	Min.	Typ.	Max.	Unit
Reference voltage	V_{ref}	$10\text{mA} \leq I_{\text{OUT}} \leq 1\text{A}, V_{\text{IN}} = 3.25\text{V}$	1.225	1.25	1.275	V
Line Regulation	ΔV_{LINE}	$I_{\text{OUT}} = 10\text{mA}, 2.75\text{V} \leq V_{\text{IN}} \leq 12\text{V}$	--	0.03	0.2	%V
Load Regulation	ΔV_{LOAD}	$10\text{mA} \leq I_{\text{OUT}} \leq 1\text{A}, V_{\text{IN}} = 2.75\text{V}$	--	2	8	mV
Dropout Voltage	V_{DROP}	$I_{\text{OUT}} = 100\text{mA}$	--	1.15	1.3	V
		$I_{\text{OUT}} = 1\text{A}$	--	1.3	1.5	V
Temperature coefficient	$\Delta V/\Delta T$		--	+100	--	ppm
Minimum load current	I_{min}		--	2	10	mA
Adjust pin current	I_{adj}	$10\text{mA} \leq I_{\text{OUT}} \leq 1\text{A}, V_{\text{IN}} = 5\text{V}$	--	55	120	μA
Iadj change	I_{change}	$10\text{mA} \leq I_{\text{OUT}} \leq 1\text{A}, V_{\text{IN}} = 5\text{V}$	--	0.2	10	μA



Typical Characteristics Curves

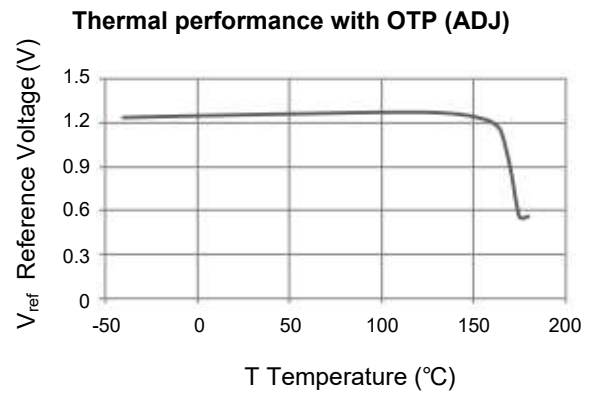
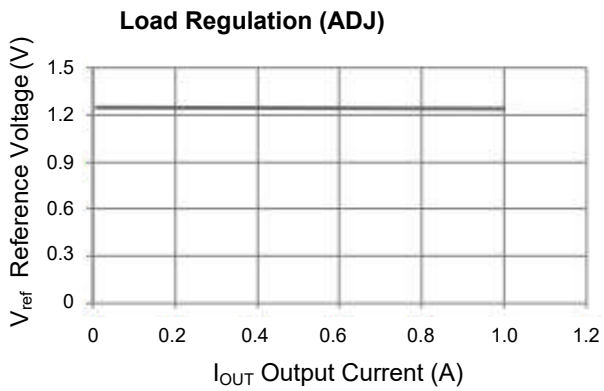
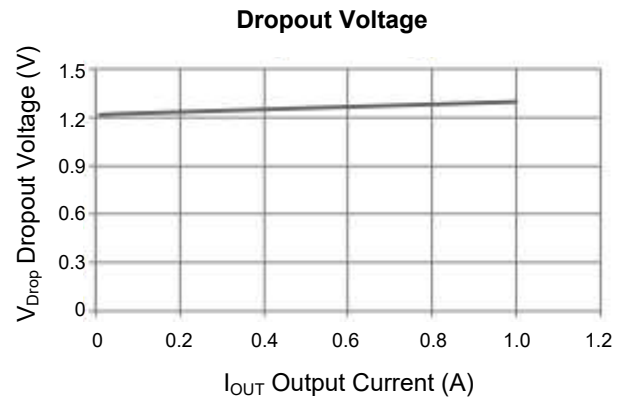
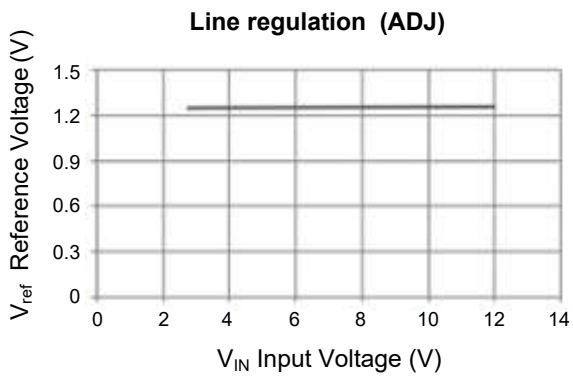



Package Outline

SOT-89

Dimensions in mm

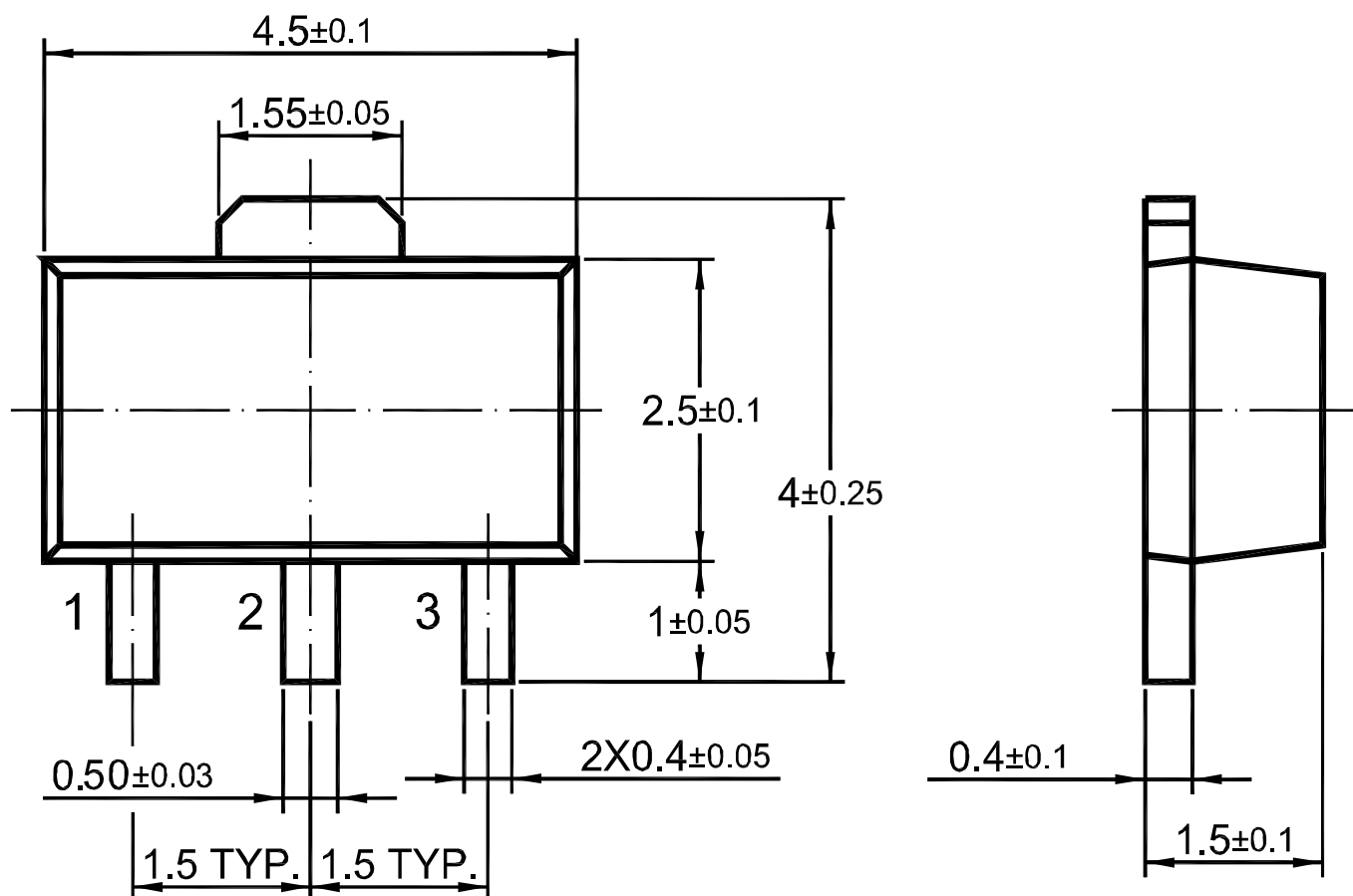

Package Outline

SOT-223

Dimensions in mm

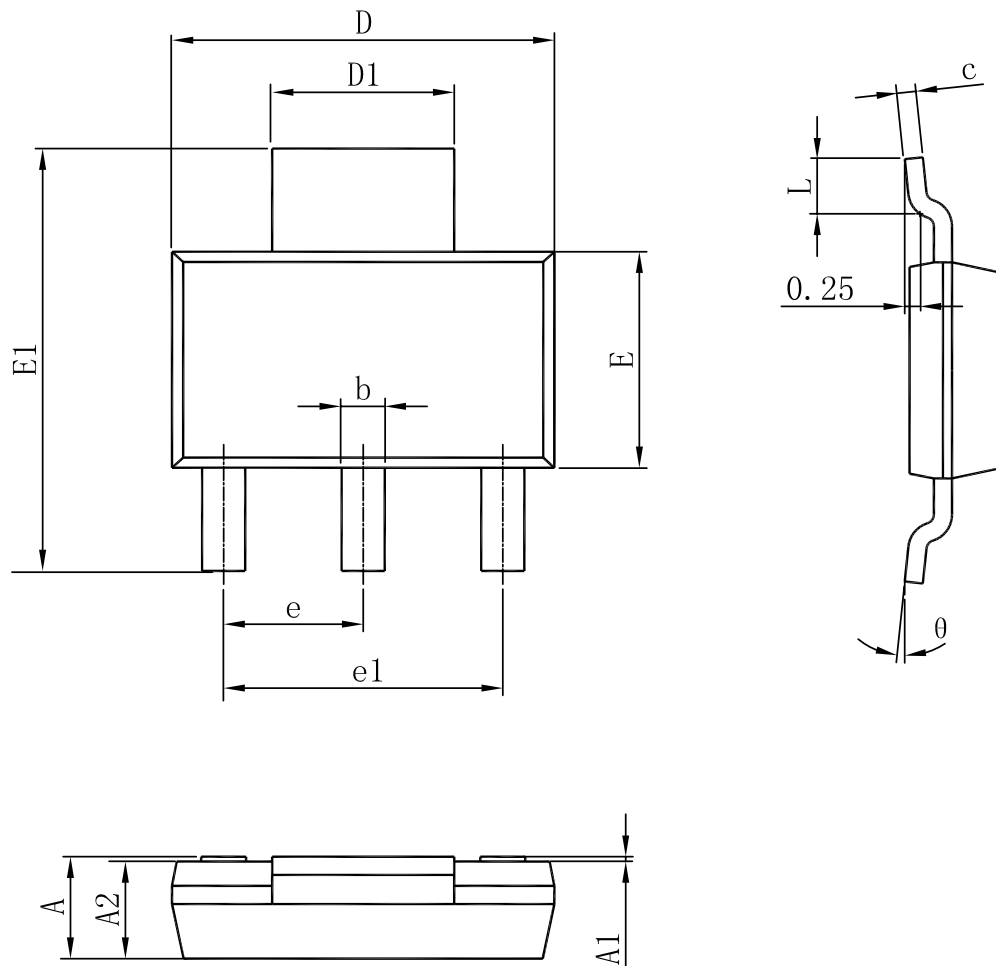

1. 塑脂体无缺损、缩孔、气泡、裂纹等缺陷；
2. 树脂体上下部XY方向偏差、树脂体中心与引线框中心错位 ± 0.035 ；
3. 粗糙度Ra为0.4--0.6。

Symbol	Dimensions In Millimeters		
	MIN	NOM	MAX
A	/	/	1.80
A1	0.02	/	0.10
A2	1.50	1.60	1.70
b	0.66	0.71	0.84
c	0.23	0.30	0.35
D	6.30	6.50	6.70
D1	2.90	3.00	3.10
E	3.30	3.50	3.70
E1	6.70	7.00	7.30
e	2.30 BASIC		
e1	4.60 BASIC		
L	0.75	/	/
θ	0°	/	10°

Package Outline

TO-252

Dimensions in mm

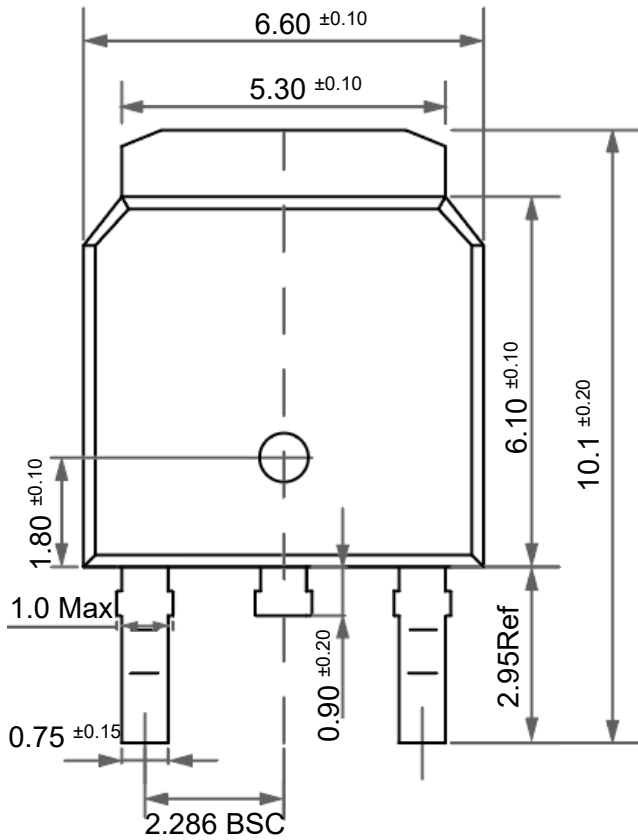

Front View

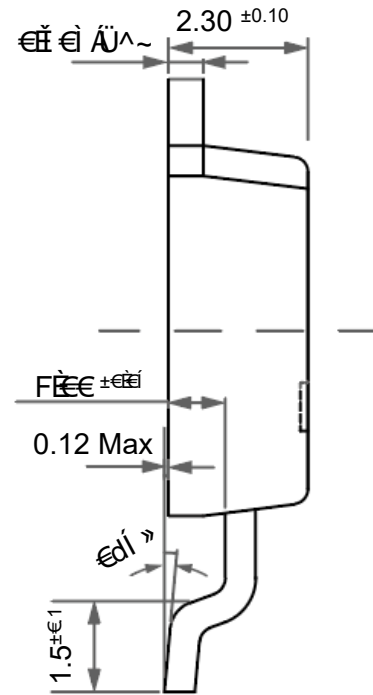

Side View

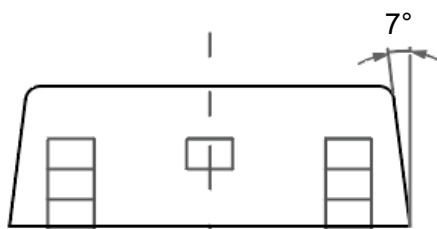

Bottom View